

Automatic Passenger Counting (APC)

# IRMA – Infrared Motion Analyzer 5<sup>th</sup> generation

## IRMA-Gateway-4-IBIS Data sheet

### Sensor versions

- IRMA MATRIX

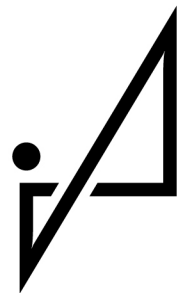

**iris** INFRARED  
INTELLIGENT  
SENSORS

## Document information

<b>Title of Document:</b>	KDDB_IRMA-Gateway-4-IBIS_1.4_en
<b>Revision:</b>	1.4
<b>Edition (yyyy-mm):</b>	2018-06
<b>Document type:</b>	Data sheet (KDDB)
<b>Status:</b>	released

## Validity

### Gateways types covered by this document:

Short description	Product name	Type designation
IRMA-Gateway	IRMA-Gateway-4-IBIS	C8-4-l-141.1.3.-16.261300.210204
		C8-4-l-141.1.3.-16.261300.210214
		C8-4-l-141.1.3.-16.261300.211214
		C8-4-l-141.1.3.-16.261300.211215

## Content

<b>1</b>	<b>General information</b> .....	<b>5</b>
1.1	Trade names.....	5
1.2	Disclaimer.....	5
1.3	Symbols and emphasis in the text.....	5
1.4	Preliminary remarks.....	5
1.5	Position of the gateway type within the analyzer family (extract).....	6
1.6	Views of the device, photos.....	7
1.7	Name plate (example).....	8
1.8	Type designation structure (extract).....	8
<b>2</b>	<b>Brief description</b> .....	<b>9</b>
<b>3</b>	<b>Block circuit diagrams</b> .....	<b>11</b>
<b>4</b>	<b>General technical data, operational parameters</b> .....	<b>12</b>
<b>5</b>	<b>Compliance with standards</b> .....	<b>13</b>
<b>6</b>	<b>Interfaces</b> .....	<b>14</b>
6.1	Power supply, "P" connector.....	14
6.1.1	„P“ Connector.....	14
6.1.2	Pin description, signal names.....	15
6.1.3	Electrical parameter values.....	15
6.2	Operating interface, "V" connector.....	17
6.2.1	"V" Connector.....	17
6.2.2	Pin description, signal names.....	18
6.2.3	Electrical parameter values.....	20
6.3	Service interface, "C" connector.....	25
6.3.1	"DSUB9" Connector.....	25
6.3.2	Pin description, signal names.....	26
6.3.3	Electrical parameter values.....	27
6.4	"CAN" sensor interface.....	29
6.4.1	"CAN" Connector.....	29
6.4.2	Electrical parameter values.....	30
<b>7</b>	<b>LED indicator</b> .....	<b>31</b>
<b>8</b>	<b>Firmware, software</b> .....	<b>32</b>
<b>9</b>	<b>Device sketches</b> .....	<b>33</b>
<b>10</b>	<b>Installation</b> .....	<b>35</b>
10.1	Selection of mounting place.....	35
10.2	Power connection diagrams, overviews, leads.....	35
<b>11</b>	<b>Abbreviations, terms</b> .....	<b>39</b>

## Figure

Fig. 1 :	Position of the type within the analyzer family (extract).....	6
Fig. 2:	View of IRMA-Gateway-4-IBIS interfaces and nameplate.....	7
Fig. 3:	View of IRMA-Gateway-4-IBIS sensor connector.....	7
Fig. 4:	Name plate (example).....	8
Fig. 5:	Overview of interfaces.....	11
Fig. 6:	Internal components.....	11
Fig. 7:	"P" connector.....	14
Fig. 8:	"V" connector.....	17
Fig.9:	DSub9 socket, view of contacts.....	25
Fig. 10:	Sketch of the "CAN" sensor interface, DSub9 connector.....	29
Fig. 11:	View of connector for the IRMA-Gateway-4-IBIS operating interfaces.....	33
Fig.12:	View from above of IRMA-Gateway-4-IBIS, attachment holes.....	33
Fig. 13:	Rear view of IRMA-Gateway-4-IBIS.....	34
Fig. 14:	IRMA-Gateway-4-IBIS, required space for the connector.....	34
Fig. 15:	Overview of door signals by means of potential free contacts.....	37
Fig. 16:	Overview of door signals by means of external control voltage (any polarity).....	38

## Tables

Table 1:	General technical data, operational parameters.....	12
Table 2:	Compliance with standards.....	13
Table 3:	Approval mark.....	13
Table 4:	Connector pin assignment, "P" power connection.....	14
Table 5:	Power supply "P", boundary values / maximum loads.....	15
Table 6:	Power supply "P", operating values.....	16
Table 7:	Operating interface "V", signals and names.....	18
Table 8:	Operating interface "V", boundary values / maximum loads.....	20
Table 9:	Operating interface "V", electrical operating values.....	22
Table 10:	Service interface "C", contact assignment.....	25
Table 11:	Service interface "C", boundary values / maximum loads.....	27
Table 12:	Service interface "C", electrical operating values.....	28
Table 13:	"CAN" sensor interface, pin assignment.....	29
Table 14:	"CAN" sensor interface, boundary values / maximum loads.....	30
Table 15:	"CAN" sensor interface, electrical operating values.....	31
Table 16:	LED, colours and statuses.....	31
Table 17:	Recommended cable types (examples).....	36

# 1 General information

## 1.1 Trade names

Unless otherwise indicated, all brand and product names in this document are the registered trade names of their respective owners.

## 1.2 Disclaimer

The information contained in this document is based on product data resulting from the development and approval phases as well as the production of initial samples. These specifications do not claim to be error-free and will need to be updated or corrected. Such modifications may be made by iris-GmbH without notice. Characteristic or typical values given are based on our experience and are approximate values to be expected; they are by no means guaranteed by iris GmbH.

## 1.3 Symbols and emphasis in the text



“Please note”



“Worth knowing”



“Caution!” Failure to observe the guidelines can result in damage to the sensor.”



“Information”



“Download”



“See document”

[link](#)

Text shown in blue and underlined indicates the possibility of going directly to another part of the text, i.e. navigating within the document (in addition to 'normal' text references).

## 1.4 Preliminary remarks

The following data sheet describes the analyzer variant 'Gateway' for IRMA MATRIX and the communication protocol "IBIS". Analyzers in this context are evaluation units of the "IRMA" people counting system. 'Gateway' and 'IRMA Gateway-4-IBIS' are synonymous. This data sheet does not describe the function or installation of the gateway in its entirety (sensors, cables, data interface, etc.), but reproduces the technical data.

## 1.5 Position of the gateway type within the analyzer family (extract)

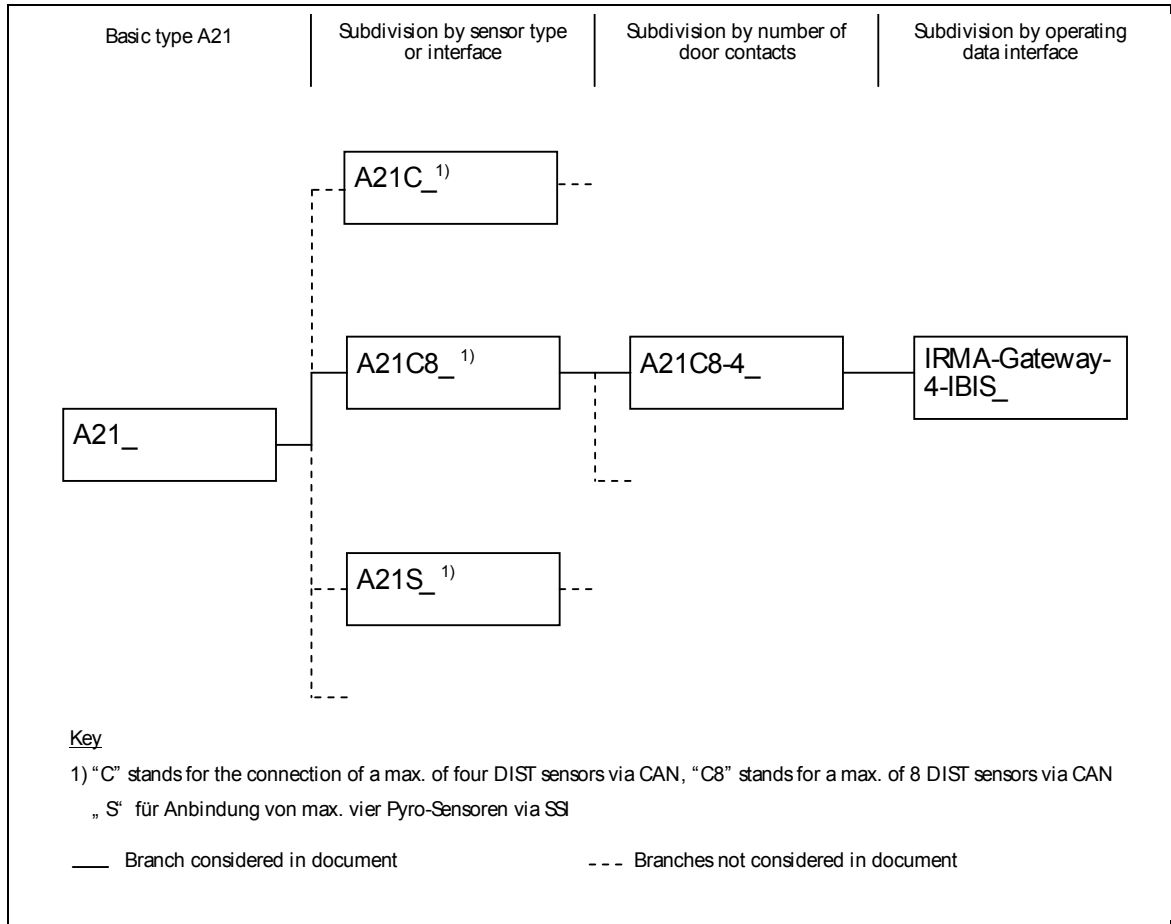

**Fig. 1 :** Position of the type within the analyzer family (extract)

## 1.6 Views of the device, photos

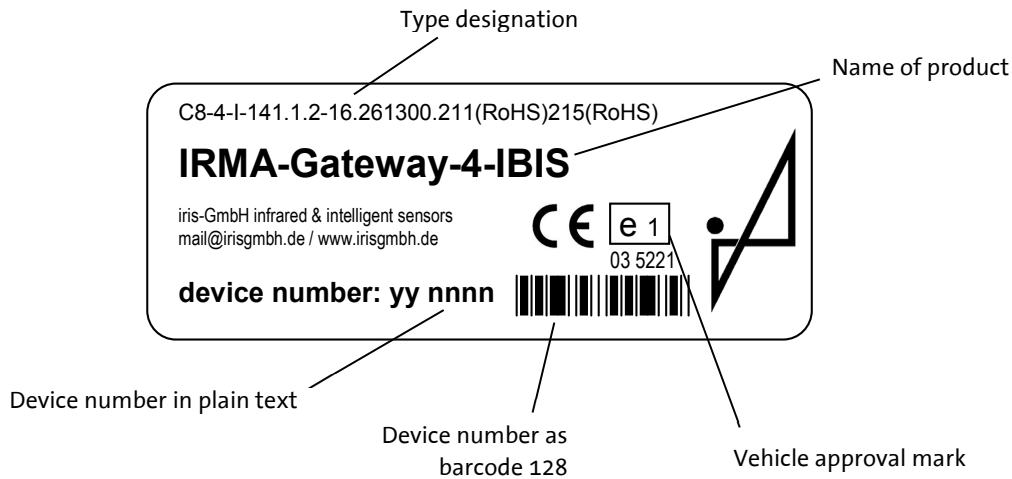

**Fig. 2:** View of IRMA-Gateway-4-IBIS interfaces and nameplate



**Fig. 3:** View of IRMA-Gateway-4-IBIS sensor connector

## 1.7 Name plate (example)



**Fig. 4:** Name plate (example)

## 1.8 Type designation structure (extract)

a(a)-4-l-ccc.1.3-16.2613rr.bbbttt  
 a(a) = C: A21C for a maximum of 4 sensors  
 Gate-  
 way = for IRMA MATRIX sensor  
 4 = 4 door signal inputs  
 l = IBIS (communication protocol)  
 ccc = 141: Housing version 1.41, four-part, IP30, base plate V1.41  
 rr = 00: No logger memory, no real-time clock  
 = 13: 128KByte  
 bbb = 210: Basic PCB "LPBG-A21C210"  
 = 211: Basisplatine „LPBG-A21C211“  
 ttt = 204: Interface module "LPBG-A21-I204"  
 = 214: Interface module "LPBG-A21-I214"  
 = 215: Interface module "LPBG-A21-I215"  
 e.g.: Gateway-4-l-141.1.3-16.261300.211215

## 2 Brief description

The IRMA-Gateway-4-IBIS interface is the IBIS interface (evaluating device) of the IRMA passenger counting system for use in public transport - busses and trains. The connected IRMA MATRIX sensors record the persons passing through the doors (boarding the vehicle and alighting from it) each stop and record the numbers for each door/passage. The counting data is sent via CAN from IRMA MATRIX to the gateway. The gateway translates the counting results according to the VDV 300 specification into the IBIS communication protocol. Communication with the on-board computer is via IBIS (VDV 300).

Depending on the system layout, up to eight IRMA MATRIX sensors can be connected to one gateway. The IRMA MATRIX sensors are mounted singly or in pairs above the (small or wide) doors. All IRMA MATRIX sensors are connected to the gateway by a common shielded cable. Wiring is linear, junctions or short branch lines provide connection to the IRMA MATRIX sensors.

Cabling is the subject of the project planning. Connection to the gateway itself is via the "CAN" connector.

["CAN" sensor interface, s. p 29](#)

Detection of the door status (start/stop of counting process) is ensured by means of four electrically isolated switching inputs (connector "V", see also figure [Fig. 2](#) "View of IRMA-Gateway-4-IBIS interfaces and nameplate"). They allow the application of external control voltages typical of on-board networks as well as the connection of potential free switches; these use an auxiliary voltage supplied by the device (the so-called door voltage).

Connection is made using unshielded individual wires.

Transmission of the counting data to an on-board computer is ensured by means of one electrically isolated data interface (also via connector "V") - here of the "IBIS" type. Connection is made using one unshielded line with twisted core pairs. Depending on the application, a shielded line can equally be used.

[Operating interface, "V" connector s. p. 17](#)

A separate "P" connector is used for the connection to the on-board network. A DC-DC converter with electrical isolation from the on-board network provides the system with the power required. It generates the voltage for the sensors and for generation of the internal logic voltages. In addition, a non-electrically isolated RS232 service interface "C" is available. It is not assigned in normal operation and is, if required, used for configuration of the system and for software downloads.

[Service interface, "C"s. p. 25](#)

A two-colour light diode (LED) signals the operating status. [LED indicators. p. 31](#)

The gateway is modular in its structure, comprising a main board and interface module (SSM), each specified to the type in question. All components are installed in a stainless-steel housing.

A central power supply, a processing core consisting of a micro-controller and memory, the CAN line driver and the RS232 service interface are all mounted on the PCB.

The IBIS operating data interface to the on-board computer and the four potential free signal inputs are contained in the interface module. It also generates the door voltage.

The firmware controls the interaction of the individual components. Software tools for the Windows PC are provided for firmware updates and visualization.

[Firmware, software s. p. 32](#)

### 3 Block circuit diagrams

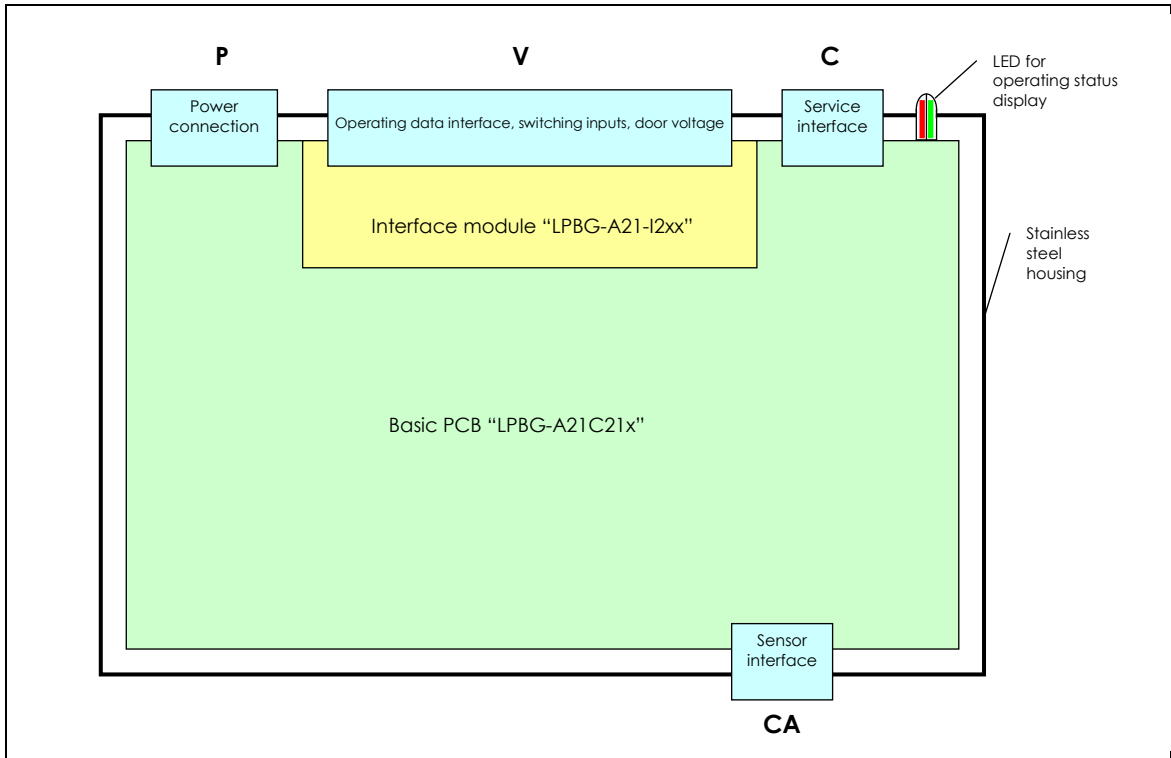

Fig. 5: Overview of interfaces

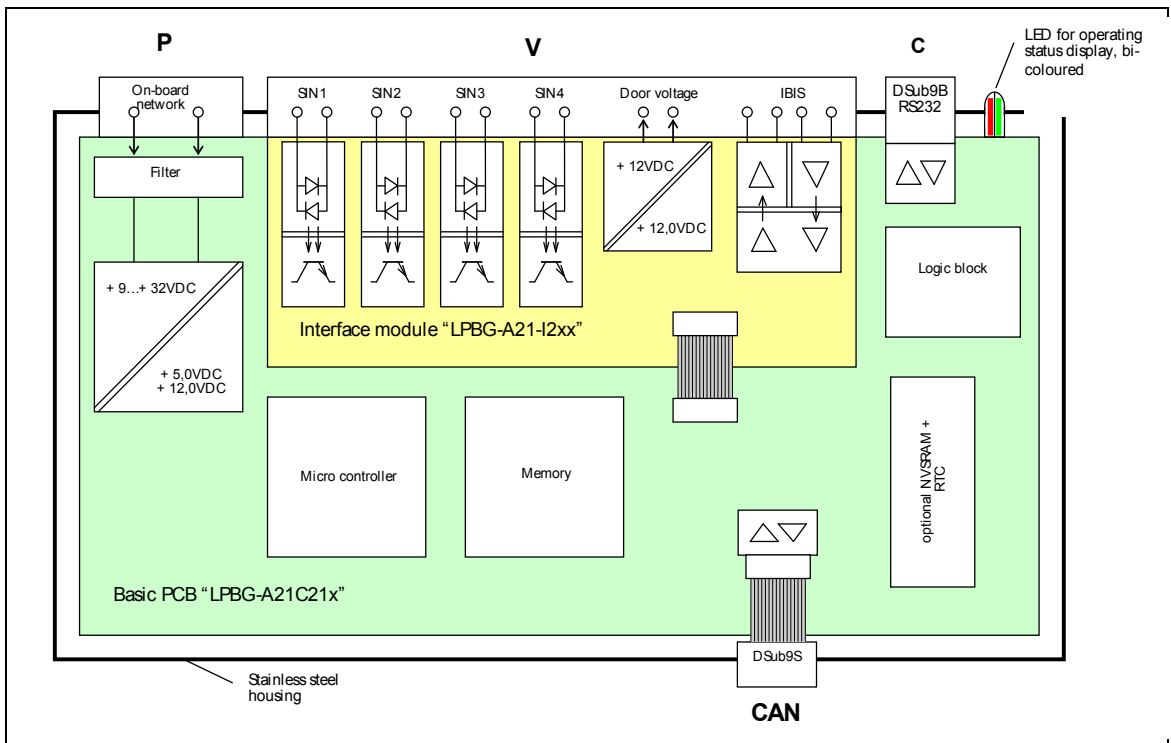

Fig. 6: Internal components

## 4 General technical data, operational parameters

Table 1: General technical data, operational parameters

Parameter	Symbol	Value	Notes
<b>Operational conditions</b>			
Power supply voltage	$U_{VP}$ in V DC	9...32	12 V or 24 V motor vehicle on-board network; electrical isolation permissible voltage fluctuation in acc. with vehicle directive and EN 50155 (cl. S2), load dump protection
Isolation voltage strength	$V_{iso}$ in kV DC	1.0	Valid for any electrical isolation
Operating temperature range	$T_A$ in °C	-25 ... +70	
Relative humidity	RH in %	$\leq 95$	Non condensing
Protection class		IP30	With housing of version 1.41
MTBF	h	$\geq 300.000$	At 25° ambient temperature
<b>Storage, transport</b>			
Temperature range	$T_A$ in °C	-40 ... +85	
Relative humidity	RH in %	$\leq 95$	Non condensing
<b>General information</b>			
Weight	in g	950...1000	depends on equipment
Dimensions over all	LxWxH in mm	198 x 125 x 62	over all
Housing material		Stainless steel 1.4301	Casing 1 mm sheet steel, base plate 2 mm sheet steel

## 5 Compliance with standards

**Table 2: Compliance with standards**

Compliance with standards, device tests			
Field	Standard, classification	Application	Test report
Rail	EN 50121-3-2	EMC	ProEMV PL090308 <sup>1)</sup>
	EN 50155	Heat, cold	Aucoteam 7136/09
	EN 50155	Voltage fluctuation and interruption	ProEMV PL090308
	EN 61373, category 1, class A	Vibration, shock loads	Aucoteam 7136/09
Road	EC directive for vehicles 2006/28/EC	EMC	ProEMV PL071128 Approval mark 03 5221
	J1455	Load dump transient protection on power line	ProEMV PL071207A PL071207A_supplementa tion <sup>3)</sup>
	VDV300	IBIS data interface	
	EN 60721-3-5, class 5M2	Vibration, shock loads (without external shock loads)	Aucoteam 7136/09
<p>Notes: If a test report is not specified, references to technical standards are considered to be design objectives, for which verification is still to be made by an independent test centre.</p> <p>1) Applies to units comprising at least LPBG-A21C211 and LPBG-A21-I215 (or higher) and shielded data lines.</p> <p>2) Applies to units with LPBG-A21C211.</p> <p>3) For similar test, see PL071207A.</p>			

**Table 3: Approval mark**

Mark	Approval No.
<div style="border: 1px solid black; display: inline-block; padding: 2px;">e 1</div> 03 5221	e1*72/245*2006/28*5221*00 e1*72/245*2006/28*5221*01

## 6 Interfaces

### 6.1 Power supply, "P" connector

The gateway IRMA-Gateway-4-IBIS is intended for operation in a 12 V or 24 V on-board network for rail or road transport. The on-board voltage is supplied via a surge filter, inverse-polarity protection and a short-term outage bridge. A DC-DC converter supplies the electrically isolated voltage required for operating the device. The DC-DC converter itself has an input current limiter and thermal surge protection. A delayed fuse ensures input in the case of a converter defect.

The on-board voltage is connected via a 4-pole "P" (power) male multipoint connector. By means of the internal bridge with two contacts in each case it is possible to pass on the current. The IRMA MATRIX sensors are powered by an **external** power supply.

#### 6.1.1 „P“ Connector

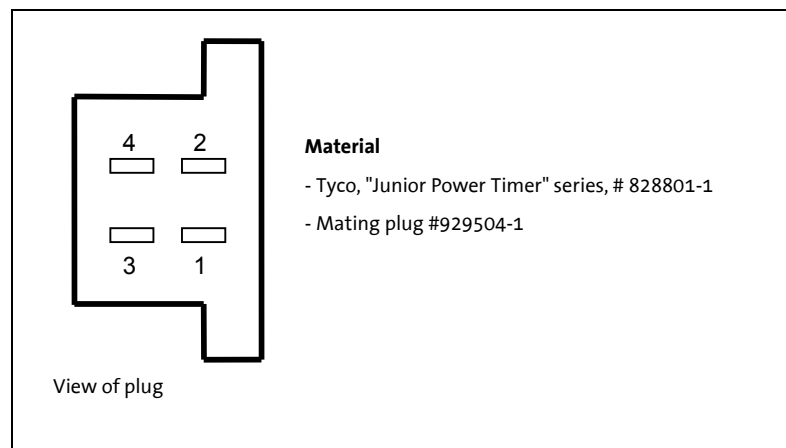

**Fig. 7:** "P" connector

**Table 4:** Connector pin assignment, "P" power connection

Pin	Signal name	Type	Application	Comments
1, 3	VP	Input	Power supply, pos. pole	Electrical isolation of housing and electronics
2, 4	GNDVP	Input	Power supply, neg. pole	

## 6.1.2 Pin description, signal names

### Power supply input "VP, GNDVP"

The power supply to be applied at the input "VP" with respect to "GNDVP" (**V**oltage**P**ower or **G**round**V**oltage**P**ower) feeds an electronically isolated DC-DC converter.

Transient protection is realized by means of a varistor and an electronic surge protection switch.

The input is protected against inverse polarity.

## 6.1.3 Electrical parameter values

Table 5: Power supply "P", boundary values / maximum loads

Boundary values / maximum loads ( $T_A = 25\text{ °C}$ , unless otherwise specified)				
Parameter	Symbol	min	max	Conditions / Comments
Power supply voltage	$V_{VP}$ in V DC	-36	+36	$t \leq 1\text{ min}$ , $R_{source} = 0\ \Omega$
		-50	+50	$t \leq 10\text{ s}$ , $R_{source} = 0\ \Omega$
		-150	+150	Impulse, $\tau = 0.4\text{ s}$ , $R_{source} = 0.8\ \Omega$ <sup>1)</sup>
Transient absorption capacitance	$W_{max}$ in J		20	Varistor in DC supply voltage input capped at 200 V at 50 A, 2 ms
Isolation voltage strength	$V_{iso}$ in kV AC		1.0	for each design, all potentials/individual wires with respect to chassis or the other interfaces
Burst, all contacts	$V_s$ in kV	-2,0	+2,0	5/50 ns, 5 kHz, wire-wire, wire-chassis
Surge, all contacts	$V_s$ in kV	-2,0	+2,0	5/50 $\mu$ s, 100 $\Omega$ , wire-wire, wire-chassis
ESD, all contacts	$V_s$ in kV	-4/-8	+4/+8	Contact/air, 150 pf, 330 $\Omega$ , cycle time $\geq 1\text{ s}$
1) Load dump impulse in accordance with SAE-J1455				

Table 6: Power supply "P", operating values

Specification / Operating values ( $T_A = 25\text{ °C}$ unless otherwise specified)					
Parameter	Symbol	min	typical	max	Conditions / Comments
Insulation resistance	in $M\Omega$	100			Test voltage 1 kV DC, all potentials/individual wires with respect to chassis
Insulation capacitance	in nF		4.7		Wire with respect to chassis
<b>Power supply voltage</b>					
Full load range	$V_{VP}$ in V	9.0		32.0	$P_{out,DCDC,min} \geq 9\text{ W}^1$ , $T_{gateway\ housing} \leq 70\text{ °C}$
Peak load range		18.0		32.0	$P_{out,DCDC,max} \geq 14\text{ W}^2$ , without heat dissipation from PCB floor plate limited over time
Power-up range		8.5		33.0	When switching on power
Idling range		7.0			At part load 4 sensors, input current limiter cuts in
				50.0	Limited over time through thermal cut-off according to load
Outage bridging time	$t_{\ddot{u}}$ in ms	10 20			C210, $P_{out,DCDC} = 9\text{ W}^3$ , $V_{VP} = 24\text{ V}$ C211, $P_{out,DCDC} = 9\text{ W}^3$ , $V_{VP} = 24\text{ V}$
Power take-up	$I_{VP}$ in A		0.5		$V_{VP} = 12\text{ V}$ , 4 sensors with 1 W
			0.25		$V_{VP} = 24\text{ V}$ , 4 sensors with 1W
			0.5		$V_{VP} = 24\text{ V}$ , 8 sensors with 1W
			1.4		$P_{out,DCDC} = 9\text{ W}$ , $V_{VP} = 9\text{ V}$
			1.0		$P_{out,DCDC} = 10\text{ W}$ , $V_{VP} = 12\text{ V}$
			0.5		$P_{out,DCDC} = 10\text{ W}$ , $V_{VP} = 24\text{ V}$
Continual defective current				5.0	in case of a defect for $t_{\square}$ internal delayed-action fuse
Switch-on surge current			8.0	10.0	$t < 10\text{ ms}$ , current limiter cuts in
<p>The energy supplied by the DC-DC converter is divided between the microcontroller core (about 1 W), the interface module (about 1 W) and the sensors (1W). At the same time we differentiate between the following cases:</p> <ol style="list-style-type: none"> <li><math>P_{out,DCDC,min}</math> is the guaranteed total output performance of the DC-DC converter at the lowest limit of the on-board voltage.</li> <li><math>P_{out,DCDC,max}</math> is the guaranteed total peak output performance (thermal activation) limited over time, of the DC-DC converter.</li> <li><math>P_{out,DCDC}</math> is the required total long-term output performance (concrete load) of the DC-DC converter.</li> </ol>					

## 6.2 Operating interface, “V” connector

The signals for detecting the door position are transmitted via the "V" (vehicle) connector and connection is made to the on-board computer. The connection is made predominantly via unshielded leads (details in section [10 "Installation", see p.35](#)).

### 6.2.1 “V” Connector

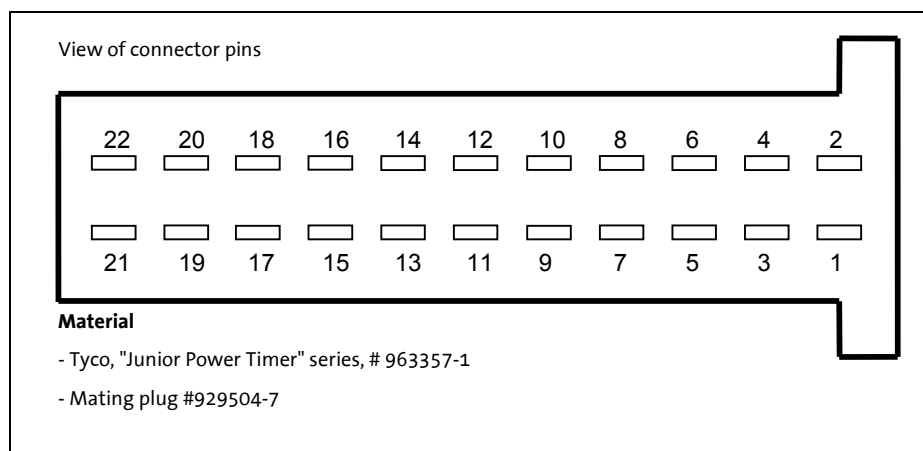

**Fig. 8:** “V” connector

## 6.2.2 Pin description, signal names

Table 7: Operating interface "V", signals and names

Pin	Name	Type	Application	Comments
<b>IBIS data interface</b>				
1	WBSD	In	<b>W</b> agen- <b>B</b> US- <b>S</b> ende- <b>D</b> aten (Vehicle bus transmission data)	electrically isolated
2	WBMS	In	<b>W</b> agen- <b>B</b> US- <b>M</b> inus- <b>S</b> enden (Vehicle bus minus transmission)	
3	WBME	Out	<b>W</b> agen- <b>B</b> US- <b>M</b> inus- <b>E</b> mpfang (Vehicle bus minus reception)	electrically isolated
4	WBED	Out	<b>W</b> agen- <b>B</b> US- <b>E</b> mpfangs- <b>D</b> aten (Vehicle bus reception data)	
5	CHGN D		Housing ground	optionally apply shield
6	CHGN D		Housing ground	optionally apply shield
<b>Door voltage</b>				
7, 11, 15, 19	GNDV D	Out	Door voltage, neg. pole	Galvanically isolated ancillary voltage output 12 V, $R_i = 100 \Omega$ , short-circuit-proof
9, 13, 17, 21	VD	Out	Door voltage, pos. pole	
<b>Door signal inputs</b>				
8	SIN1b	In	Switching input_1, contact "b"	Galvanically isolated, polarity-independent, $U_{in,max} = 36 \text{ V}$ , $U_{trip} = 6...9 \text{ V}$ , $R_i = 22 \text{ k}\Omega$ plus constant current sink 5 mA
10	SIN1a	In	Switching input_1, contact "a"	
12	SIN2b	In	Switching input_2, contact "b"	Galvanically isolated, polarity-independent, $U_{in,max} = 36 \text{ V}$ , $U_{trip} = 6...9 \text{ V}$ , $R_i = 22 \text{ k}\Omega$ plus constant current sink 5 mA
14	SIN2a	In	Switching input_2, contact "a"	
16	SIN3b	In	Switching input_3, contact "b"	Galvanically isolated, polarity-independent, $U_{in,max} = 36 \text{ V}$ , $U_{trip} = 6...9 \text{ V}$ , $R_i = 22 \text{ k}\Omega$ plus constant current sink 5 mA
18	SIN3a	In	Switching input_3, contact "a"	
20	SIN4b	In	Switching input_4, contact "b"	Galvanically isolated, polarity-independent, $U_{in,max} = 36 \text{ V}$ , $U_{trip} = 6...9 \text{ V}$ , $R_i = 22 \text{ k}\Omega$ plus constant current sink 5 mA
22	SIN4a	In	Switching input_4, contact "a"	

### Door voltage "VD, GNDVD"

An ancillary galvanically isolated voltage, proof against short circuits, is supplied by the device for controlling the switching inputs when potential free contacts are used. It is proof against accidental loading with the on-board voltage.



Care must be taken that when using the door voltage for several switching inputs the potential isolation between these inputs is eliminated.

### "SINx" switching inputs

The "SINx" switching inputs (SSM-Input) are potential free and optically isolated digital control inputs. In the standard operation they are used as door signal inputs. Any polarity of the control voltage can be used, i.e. the input works independently of the direction of current. The additional identification with "a" or "b" is only made for organisational reasons.

The input resistance arises from the parallel switching of a 22 kΩ resistor and a current sink. At zero values of voltages the electrical resistance serves the purpose of a base load (for "checking out" the lines). The current sink functions as a resistor dependent on voltage. With an increasing control voltage value, the input resistance increases too. Hence increasing losses are avoided at high control voltage values. On the other hand a certain minimum current flows at low values of control voltage in order for example to ensure the function of the line break monitoring ( $R \leq 1.7 \text{ k}\Omega$  at 4.6 V).

### IBIS data lines „WBSD, WBMS, WBME, WBED“

A 4-wire port is available for serial communication with the on-board computer. Hardware arrangement and connection, levels, timing, etc. conform to the "IBIS standard" pursuant to VDV300. Here the gateway is to be considered as an IBIS peripheral device.

The transmitter is designed as a MOSFET switching stage with current limiting. This means that in the event of an overload the current is initially limited to a safe level, and subsequently, depending on the degree of overload, the stage switches off completely. This helps tolerate short interference pulse currents, during long-term overload the transistor is thermally loaded only to a minimum extent. Thus the circuit arrangement is proof against accidental connection to the on-board network. An inverse-polarity protection diode protects against negative interference voltages and against accidental polarity inversion.

The receiver is designed as a constant current sink with opto-coupler. A clear switching hysteresis is realized using an additional transistor circuit. Here as well an inverse-polarity protection diode protects against negative interference voltages and against accidental polarity inversion.

### "CHGND" potential

When shielded lines are used (which is not compulsory) the shield may be connected to the "CHGND" contact which is internally connected with the housing.



To avoid ground loops, the galvanic connection of the screen on one side only is recommended. In order to also achieve a good shielding effect in high frequency range, the other end should be connected to ground potential via a capacitor. The concrete execution has to be checked project-specifically.

For information on the practical realisation of wiring see section [10 "Installation", p. 35](#)

## 6.2.3 Electrical parameter values

Table 8: Operating interface "V", boundary values / maximum loads

Boundary values / maximum loads ( $T_A = 25\text{ °C}$ , unless otherwise specified)				
Parameter	Symbol	min.	max.	Conditions / Comments
<b>"SINxa, b" switching inputs</b>				
Burst	$V_s$ in kV	-2.0	+2.0	5/50 ns, 5 kHz, wire-wire, wire-chassis
Surge	$V_s$ in kV	-2.0	+2.0	5/50 $\mu$ s, 100 $\Omega$ , wire-wire, wire-chassis
ESD	$V_s$ in kV	-4/-8	+4/+8	Contact/air, 150 pf, 330 $\Omega$ , cycle time $\geq 1$ s
Isolation voltage strength	$V_{iso}$ in kV AC		1.0	Per design, all potentials with respect to other potentials
Overvoltage resistance	$V_{max,SIN}$ in V DC	-48	+48	$t \rightarrow \infty$ , $R_{source} = 0\ \Omega$
		-54	+54	$t \leq 1$ min, $R_{source} = 0\ \Omega$
		Tested with SINa with respect to SINb		

<b>Boundary values / maximum loads (<math>T_A = 25\text{ °C}</math>, unless otherwise specified)</b>				
<b>Door voltage "VD-GNDVD"</b>				
<b>Parameter</b>	<b>Symbol</b>	<b>min.</b>	<b>max.</b>	<b>Conditions / Comments</b>
Burst	$V_s$ in kV	-2.0	+2.0	5/50 ns, 5 kHz, wire-wire, wire-chassis
Surge	$V_s$ in kV	-2.0	+2,0	5/50 $\mu$ s, 100 $\Omega$ wire-wire, wire-chassis
ESD	$V_s$ in kV	-4/-8	+4/+8	Contact/air, 150 pf, 330 $\Omega$ , cycle time $\geq 1$ s
Isolation voltage strength	$V_{iso}$ in kV AC		1.0	Per design, all potentials with respect to other potentials
Overvoltage resistance	$V_{max,VD}$ in V DC	-32	+48	$t \rightarrow \infty$ , $R_{source} = 0\ \Omega$
		-32	+54	$t \leq 1$ min, $R_{source} = 0\ \Omega$
		Tested with VD with respect to GNDVD		
Transient absorption capacitance	$W_{max}$ in J		1.3	48 V Transguard, 1210
<b>IBIS data interface "WBSD, WBMS, WBME, WBED"</b>				
Burst	$V_s$ in kV	-1.0 -2.0	+1.0 +2.0	5/50 ns, 5 kHz, 15 ms/300 ms, wire-chassis I204, I214 I215
Surge	$V_s$ in kV	-2.0	+2.0	5/50 $\mu$ s, 100 $\Omega$ , wire-wire, wire-chassis
ESD	$V_s$ in kV	-2/-4	+2/+4	Contact/air, 150 pf, 330 $\Omega$ , cycle time $\geq 1$ s
Isolation voltage strength	$V_{iso}$ in kV AC		1.0	Per design, all potentials with respect to other potentials
Overvoltage resistance	$V_{max}$ in V DC	-48	+48	$t \rightarrow \infty$ , $R_{source} = 0\ \Omega$
		-54	+54	$t \leq 1$ min, $R_{source} = 0\ \Omega$
		Tested with WBSD with respect to WBMS and WBED with respect to WBME		
Transient absorption capacitance	$W_{max}$ in J		1,2	48 V Transguard, 1210
Note: These values have been fixed as shown for the design, but have not been tested in each case as these are not necessarily part of the tests for the relevant standard.				

Table 9: Operating interface "V", electrical operating values

Specification / Operating parameters ( $T_A = 25\text{ °C}$ unless otherwise specified)					
Parameter	Symbol	min.	typ.	max.	Conditions / Comments
<b>"SINxa, b" switching inputs</b>					
Insulation resistance	$R_{iso}$ in $M\Omega$	100			For isolated potentials, test voltage 1 kV DC
Insulation capacitance	$C_{iso}$ in nF		4.7		For isolated potentials
Switching voltage	$V_{in}$ in V	-6.5		+6.5	for logical L, for P2.0x $\geq 4.5$ V
			$\pm 7.5$		Step-change point, for P2.0x $\approx 2.5$ V
		-32.0		-8.5	for logical H, for P2.0x $\leq 0.5$ V
		+8.5		+32.0	
		The transition zone between H and L and vice versa is undefined and is considered to be a "forbidden" zone (switching input)			
max. switching frequency	$f_{sw}$ in kHz			1.0	
Input resistance	$R_{in}$ in $k\Omega$		22		$V_{in} = 0$ V
			1.3		$V_{in} = 4.6$ V
				1.7	$V_{in} = 4.6$ V and $T_A = -25...85\text{ °C}$
			1.1		$V_{in} = 6.5$ V
			1.3		$V_{in} = 8.5$ V
			1.8		$V_{in} = 12.0$ V
			2.9		$V_{in} = 24.0$ V
			3.3		$V_{in} = 32$ V
<b>Ancillary voltage output / door voltage "VD-GNDVD"</b>					
Insulation resistance	$R_{iso}$ in $M\Omega$	100			For isolated potentials, test voltage 1 kV DC
Insulation capacitance	$C_{iso}$ in nF		4.7		For isolated potentials
Output voltage	$V_{VD}$ in V		24.0	32.0	Idling
			12.0		$R_{load} = 4$ switching inputs
			9.5		$R_{load} = 220\ \Omega$
Short circuit current	$I_{max,VD}$ in mA			150	Sustained, protection by PTC

Specification / Operating parameters ( $T_A = 25\text{ °C}$ unless otherwise specified)					
Parameter	Symbol	min.	typ.	max.	Conditions / Comments
<b>IBIS transmitters "WBME, WBED"</b>					
Insulation resistance	$R_{iso}$ in $M\Omega$	100			For isolated potentials, test voltage 1 kV DC
Insulation capacitance	$C_{iso}$ in nF			1.0	Wire - isolated potential
Input capacitance	$C_{in}$ in pF			500	Wire - wire
Permissible bus load capacitance	$C_{load, bus}$ in nF		66.5	100	at 1200 baud between wire and wire without triggering of the overload shutdown at the shifting flanks
				300	reduced baud rate, triggering of overload shutdown
Max. switching current, static	$I_{max}$ in mA		200	100	$T_A = 70\text{ °C}$
Internal current limitation	$I_{limit}$ in A		1.0		limited in time, then automatic shutdown
Overcurrent switch-off time	$t_{limit}$ in $\mu s$		150		I2x4 at 500 mA
	$t_{limit}$ in s			5	I215 at 500 mA
Residual voltage	$V_{WBED, WBME}$ in V		1.3	2.0	in conducting condition, 100 mA
			2.0		in conducting condition, 200 mA
Operating delay L→H	$t_{V, L\rightarrow H}$ in $\mu s$		0.4	0.6	24 V, 10%
Rise time L→H	$t_{L\rightarrow H}$ in $\mu s$		0.2	0.6	24 V, 10%-90%
Operating delay H→L	$t_{V, L\rightarrow H}$ in $\mu s$		0.4	1.0	24 V, 90%
Rise time H→L	$t_{L\rightarrow H}$ in $\mu s$		0.4	3.0	24 V, 90%-10%
Baud rate	B in bit/s		1200	38400	

<b>Specification / Operating parameters (<math>T_A = 25\text{ °C}</math> unless otherwise specified)</b>					
<b>Parameter</b>	<b>Symbol</b>	<b>min.</b>	<b>typ.</b>	<b>max.</b>	<b>Conditions / Comments</b>
Insulation resistance	$R_{iso}$ in $M\Omega$	100			For isolated potentials, test voltage 1 kV DC
Insulation capacitance	$C_{iso}$ in nF			1.0	Wire - isolated potential
Input capacitance	$C_{in}$ in pF			500	Wire - wire
Input resistance	$R_{in}$ in $k\Omega$	1.0			
			4.0		at 6.0 V
			4.5		at 9.0 V; still L level
			2.0		at 9.0 V; still H level
			2.0		at 12.0 V
			3.7		at 24.0 V
			5.0		at 32.0 V
			6.4		at 48.0 V
Input voltage for H level	$V_{WBSD, WBMS}$ in V		11.0	12.0	
Input voltage for L level	$V_{WBSD, WBMS}$ in V	6.0	6.5		
Switching hysteresis	$V_{hys}$ in V		4.5		L→H→L transition
Operating delay H	$t_{V,L\rightarrow H}$ in $\mu s$		1.6		
Operating delay L	$t_{V,L\rightarrow H}$ in $\mu s$		0.2		
Baud rate	B in bit/s		1200	38400	

## 6.3 Service interface, "C" connector

The service interface is a serial communication interface with the PC in accordance with the RS232 standard. It is instrumental in putting the device into operation, and configuring and servicing it. The interface is not electrically isolated.

An ancillary voltage output (Pin\_6) is designed for supplying current for - among other devices - interface converters.

The connection to a PC is made by a shielded 1:1 lead (standard extension, iris ordering number: K-A21-C-RS232-01).

### 6.3.1 "DSUB9" Connector

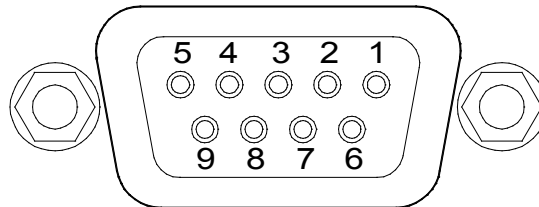

**Fig.9: DSub9 socket, view of contacts**

**Table 10: Service interface "C", contact assignment**

Contact	Signal name	Type	Application	Comments
1				Not assigned
2	RD	Output	Read Data Line	
3	TD	Input	Transmit Data Line	
4	DTR	Input	Data Terminal Ready	For switching over to the initial loading mode when powering up
5	GND			
6	+12V	Output	Ancillary voltage output	max. 100 mA
7	RTS	Input	Request To Send	
8	CTS	Output	Clear To Send	
9				Not assigned
Housing	GND		Chassis	Shielding

## 6.3.2 Pin description, signal names

### Data lines "RD" and "TD"

The minimum requirements for data communication are the lines "RD" (read by PC) and "TD" (transmit by PC).

### Handshake lines "RTS" and "CTS"

These two lines signal to the other device in each case the request (RTS) and the readiness (CTS) for transmitting.

### Control line "DTR"

For switching over to the initial loading mode (LED yellow) the control input "DTR" is used. For this purpose at the moment of powering this signal is changed to logical H (for level see [Table 12, p. 28](#)).

Counting mode (normal operation)  $U_{DTR} = \text{logical L or open}$

Initial loading mode  $U_{DTR} = \text{logical H at the moment of switching-on}$

### Ancillary voltage output +12 V

For the power supply for interface converters to be connected directly at the RS232 interface a voltage protected against an overload current will be provided.

### 6.3.3 Electrical parameter values

Table 11: Service interface "C", boundary values / maximum loads

Boundary values / maximum loads ( $T_A = 25\text{ °C}$ unless otherwise specified)				
Parameter	Symbol	min.	max.	Conditions / Comments
<b>Signal lines</b>				
Max. voltage at the RD, CTS outputs	$V_{\max}$ in V	-13.2	+13.2	
Max. voltage at the TD, RTS, DTR inputs	$V_{\max}$ in V	-25.0	+25.0	
<b>Ancillary voltage output</b>				
Max. voltage	$V_{\max}$ in V	-0.4	+30.0	$t \rightarrow \infty$ , depending on varistor and inverse polarity protection diode
<b>Shielding</b>				
Burst	$V_s$ in kV	-2.0	+2.0	5/50 ns, 5 kHz
Surge	$V_s$ in kV	-2.0	+2.0	5/50 $\mu$ s, 100 $\Omega$
<b>All pins and shielding</b>				
ESD	$V_s$ in kV	-4/-8	+4/+8	Contact/air, 150 pf, 330 $\Omega$ , cycle time $\geq 1$ s
<p>N.B.</p> <ul style="list-style-type: none"> <li>- Further information on the boundary values can be found in Maxim's data sheet "MAX3223E" and in the EIA/TIA-232-F standard.</li> <li>- The RS232 signals cannot be sustained or only partly sustained when continuously produced in connection with the 12/24 V on-board network.</li> <li>- These values have been fixed as shown for the design, but have not been tested in each case as these are not necessarily part of the tests for the relevant standard.</li> </ul>				

Table 12: Service interface "C", electrical operating values

Specification / operating values ( $T_A = 25^\circ\text{C}$ unless otherwise specified)					
Parameter	Symbol	min.	Type	max.	Conditions / Comments
Baud rate	Baud	300		34800	All standard baud rates in the range
<b>Data lines</b>					
Transmitter output voltage RD, CTS	$V_o$ in V	5.0	5.4		
Input voltage range for receiver, TD, RTS, DTR	$V_{in}$ in V	-25		+25	
Trigger point for receiver TD, RTS, DTR	$V_{in}$ in V	0.8	1.5		or open for logical L
			1.8	2.4	for logical H
		Typically 300 mV hysteresis for switching over, typically 5 k $\Omega$ input resistance			
<b>Ancillary voltage output</b>					
Output voltage	$V_{+12V}$ in V	11.0		12,25	
Output current	$I_{+12V}$ in mA			100	via Polyswitch 200 mA

## 6.4 "CAN" sensor interface

For connecting 1 to 8 IRMA MATRIX sensors (according to gateway type) a 4-wire, shielded CAN BUS system is used (2 x signal, 2 x power). The maximum quantity of the connectible sensors depends on the performance and is determined by both the required performance of the sensors and the system configuration.

The BUS system has a linear structure, the sensors are connected via short branch lines (a max. of 30 cm at 1 Mbits-1) and a distributor connector. At the outermost line ends the system must be terminated with  $120\ \Omega$  between CAN\_H and CAN\_L.

### 6.4.1 "CAN" Connector

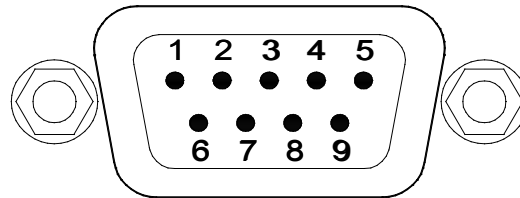

**Fig. 10:** Sketch of the "CAN" sensor interface, DSub9 connector

**Table 13:** "CAN" sensor interface, pin assignment

Pin	Signal name	Type	Application
1	NC		Not assigned
2	CAN_L	IO	CAN signal L
3	CAN_GND		Ground
4	NC		Not assigned
5	NC		Not assigned
6	CAN_GND		Ground
7	CAN_H	IO	CAN signal H
8	NC		Not assigned
9	CAN_V+	Power	Sensor power supply
10	NC		Not assigned

## 6.4.2 Electrical parameter values

**Table 14: "CAN" sensor interface, boundary values / maximum loads**

<b>Boundary values / maximum loads (<math>T_A = 25^\circ\text{C}</math> unless otherwise specified)</b>				
<b>Parameter</b>	<b>Symbol</b>	<b>min.</b>	<b>max.</b>	<b>Conditions / Comments</b>
Transient absorption capacity	$W_{\max}$ in J		0,1	Limiting through varistor at 65 V at 2 A
<b>Data "CAN_H" and "CAN_L"</b>				
Voltage resistance	$V_{\text{CAN\_H}},$ $V_{\text{CAN\_L}}$ in V DC	-27	+30	$t \rightarrow \infty, R_{\text{source}} = 0 \Omega$ , max. continuous operating voltage of varistor
		-27	+35	$t \leq 1$ min, $R_{\text{source}} = 0 \Omega$ , limiting through varistor
Transient absorption capacity	$W_{\max}$ in J		0.1	30 V Transguard, 0805
<b>Shielding</b>				
Burst	$V_s$ in kV	-2.0	+2.0	5/50 ns, 5 kHz
Surge	$V_s$ in kV	-2.0	+2.0	5/50 $\mu\text{s}$ , 100 $\Omega$
<b>All pins and shielding</b>				
ESD	$V_s$ in kV	-4/-8	+4/+8	Contact/air, 150 pf, 330 $\Omega$
N.B. These values have been fixed as shown for the design, but have not been tested in each case as these are not necessarily part of the tests for the relevant standard.				

**Table 15: "CAN" sensor interface, electrical operating values**

Specification / operating values ( $T_A = 25\text{ }^\circ\text{C}$ unless otherwise specified)					
Parameter	Symbol	min.	Type	max.	Conditions / Comments
<b>Data "CAN_H" and "CAN_L"</b>					
Capacitance CAN_L, CAN_H with respect to CAN_GND	C in pF		100		In the form of Transguards
Line end CAN_L with respect to CAN_H	Z in k $\Omega$		3.0		T network 2 x 1.5 k $\Omega$ in series, centre point with 100 nF with respect to CAN_GND
Signal voltages	Vo in V	0		5.25	see Philips data sheet TJA1040
Baud rate	in kBaud			1000	

## 7 LED indicator

Various LED colours reveal the following operating statuses:

**Table 16: LED, colours and statuses**

Colour	Operating status
Off	Out of operation
Red	Reset during power-up, initialisation
Yellow	Initial loading mode
Green	Counting mode ready

## 8 Firmware, software

The firmware (software on the device) controls the interaction of the individual components (IRMA MATRIX sensor, gateway and on-board computer).



The IRMA MATRIX sensor generates the passenger count data itself (it has a firmware and all necessary configurations). IRMA MATRIX transmits these counting results via CAN to the gateway, which converts the counting results into another protocol (IBIS) and sends them to the on-board computer via the VDV 300 interface. Here, the count data can be processed further.

This firmware is already loaded on delivery, but can be loaded or overwritten at any time via the "C" interface.

Example of firmware:

- GDIST500\_AA21C\_CI-6.00-20130528.HEX

For software downloads and for configuration and visualization, software tools are provided for the Windows® PC - such as the package "IRMA-A21-Tools", which can be downloaded via <https://www.irisgmbh.de/en/technical-documents/service-software/>.

The framework program "IRMA-A21-Windows" for putting the system in operation and for data visualization includes additional components like:

- "A21\_Boot" for firmware download and update



The IRMA gateways support multiple baud rates. IRMA-Gateway-4-IBIS arbeitet standardmäßig mit **1200 Baud**. Before changing the gateway baud rate, please consult the responsible project engineer of iris-GmbH.

## 9 Device sketches

**!** Note: The drawings are not to scale; all specified dimensions are in millimetres.

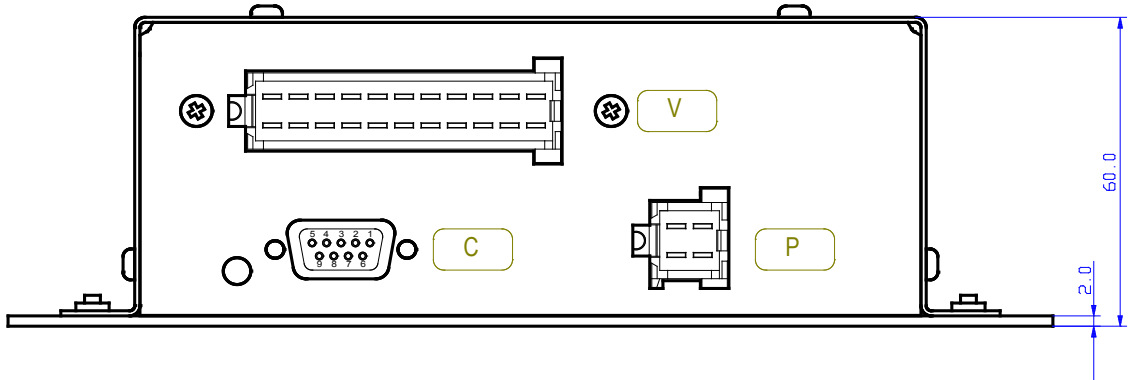

**Fig. 11:** View of connector for the IRMA-Gateway-4-IBIS operating interfaces

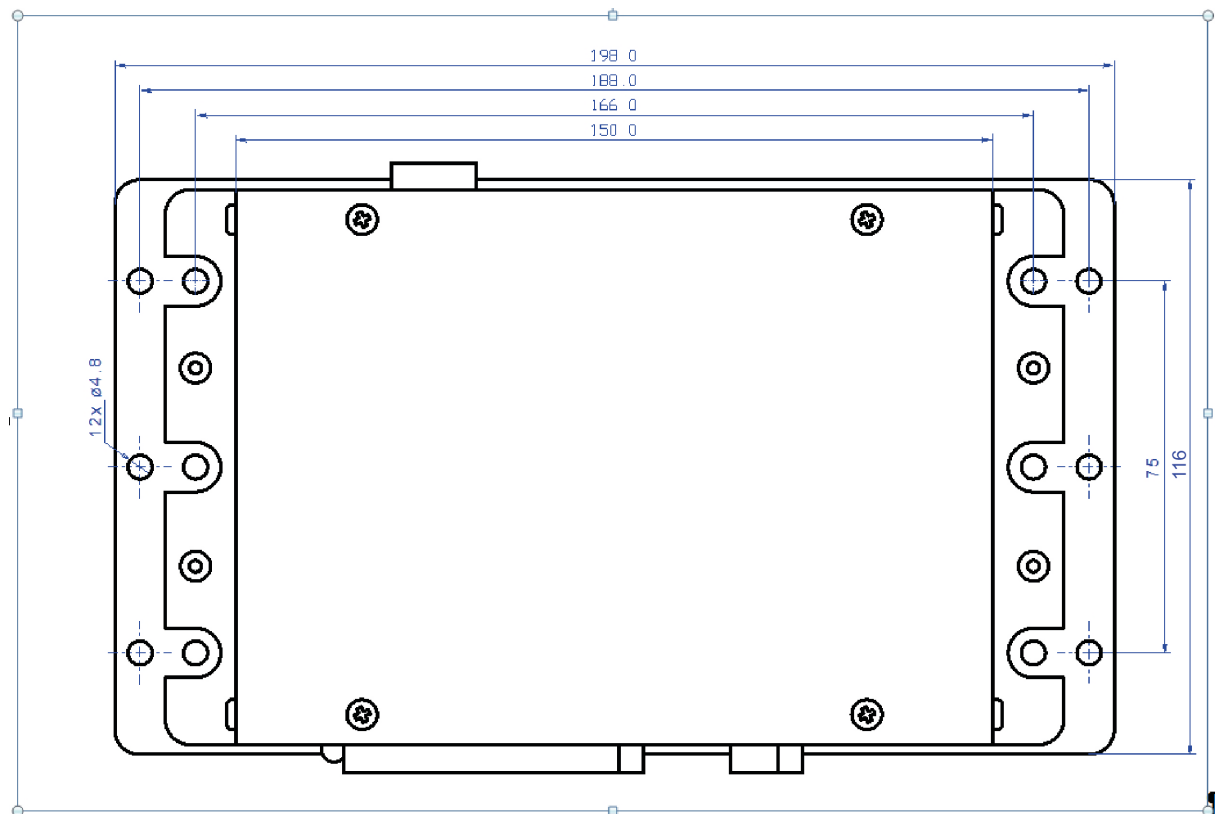

**Fig.12:** View from above of IRMA-Gateway-4-IBIS, attachment holes

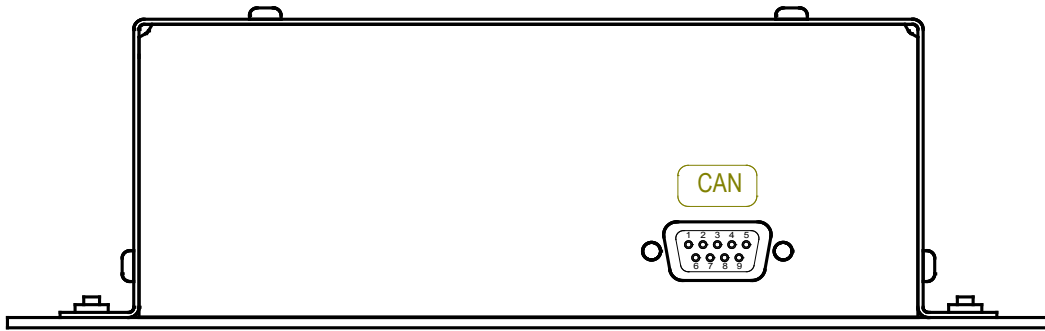

Fig. 13: Rear view of IRMA-Gateway-4-IBIS

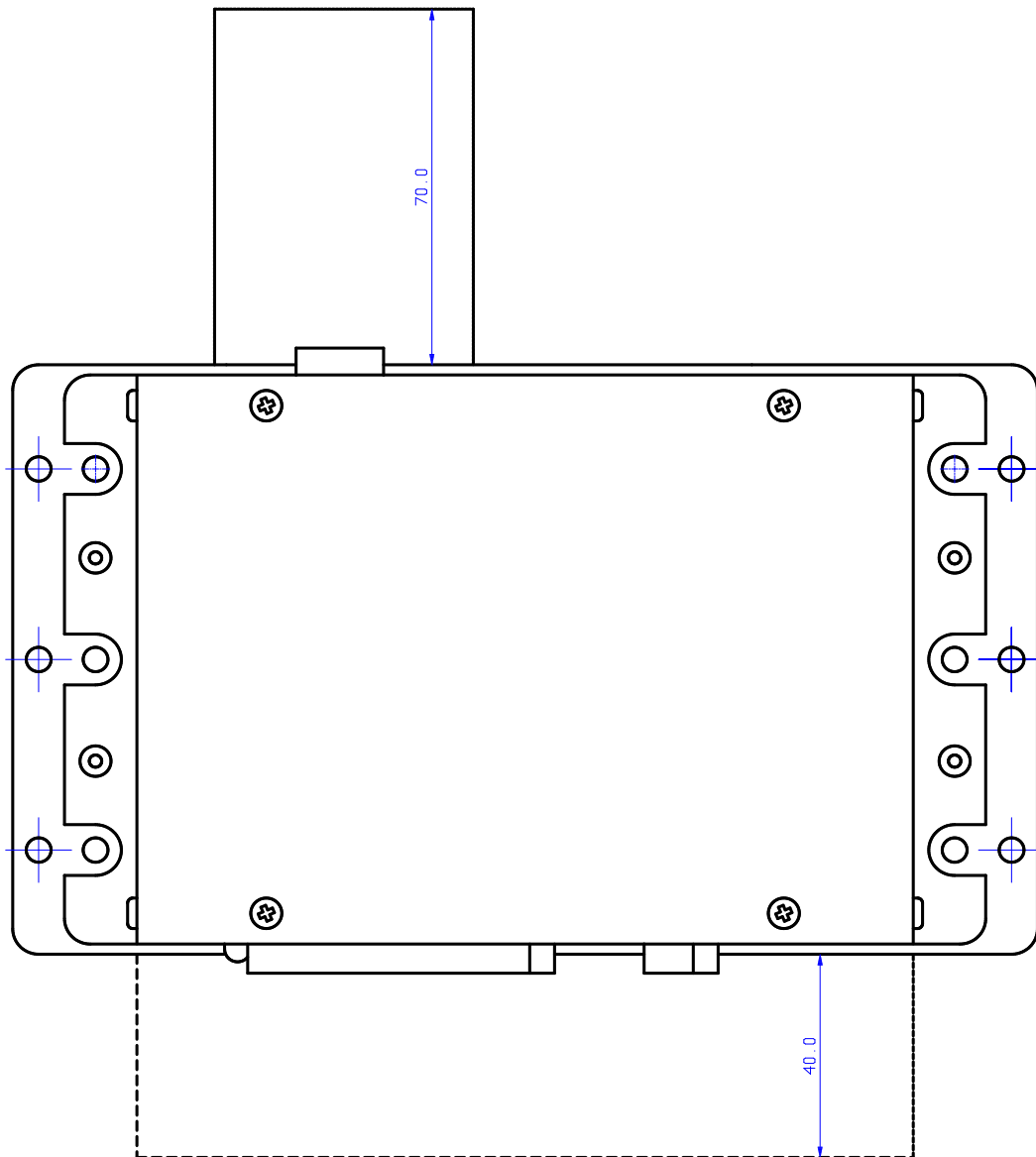

Fig. 14: IRMA-Gateway-4-IBIS, required space for the connector

## 10 Installation

### 10.1 Selection of mounting place



The device must be located in the vehicle interior so that the following conditions are observed:

- It must be ensured that the permissible operating temperature range is observed, i.e.:
  - do not install the device on an outside vehicle wall where it is exposed to solar radiation,
  - do not install the device in locations where there is a risk of heat build-up.
- The device must not be installed in locations exposed to dust or wear particles such as near rods, belt drives or in exhaust air ducts.
- The device must not be installed in locations exposed to air currents that favour condensation because of their temperature or moisture content.
- The device must not be installed on vibrating structural components or those exposed to impact loads.

Furthermore, when installing the device, care should be taken that a reliable earthed connection is made with the vehicle chassis that has a low electrical resistance and is protected against corrosion. This means that, where applicable, paint should be removed from at least one attachment hole on the chassis side and a tooth-lock washer used. For an insulated installation, an additional earthing cable, strip or stranded wire with a cross section of at least 10 mm<sup>2</sup> and a maximum length of 30 cm should be used.

### 10.2 Power connection diagrams, overviews, leads

For connecting the operating voltage and door contacts unshielded leads can be used in the form of individual flexible single-core cables.

For connecting the data interface flexible shielded control lines with twisted core pairs (TP) are recommended - for rail vehicle applications they are compulsory to observe the EMC requirements, whereas for road vehicles they are not compulsory.

The manufacturer offers pre-assembled cables. These are available in various qualities: flame-proof, halogen free yes/no and different lengths.

The lengths are to be specified when ordering the cables (the variables X, Y, Z, A, B are for lengths in metres).

**Table 17: Recommended cable types (examples)**

Connection	Cable type	Comments
Potential free contacts + IBIS interface	K-A21-V-IBIS-08-X-Y-Z-A-Bm	LiY 0.75 mm <sup>2</sup> + LiYCY TP 2 x 2 x 0.75 mm <sup>2</sup> (PVC)
External control voltage + IBIS interface	K-A21-V-IBIS-07-X-Y-Z-A-Bm	LiY, 0.75 mm <sup>2</sup> + LiYCY TP 2 x 2 x 0.75 mm <sup>2</sup> (PVC)
Power	K-A21-P-01-xm	LiY, 1 mm <sup>2</sup> (PVC)
	K-A21-P-02-xm	LiH, 1 mm <sup>2</sup> (FRNC)
	K-A21-P-03-xm	LiH, 1 mm <sup>2</sup> (halogen-free)

-  Generally for the IBIS data lines twisted wire pairs must be used - one pair each for transmitting and receiving - for railway applications additionally with complete shield. This is the only way to fulfil the EMC requirements.

Connecting the door signals can be carried out in two ways:

- Application of potential free contacts (using the door voltage supplied by the device)
- Application of external control voltages.

Door signal detection functions independently of polarity. The control voltage polarity can be set one way or another.

-  The transmission of the door signals is in general via 2-wire pairs. This means that both poles of the door signal input should be connected to the source. If individual wiring strands are used, these should be close together - and ideally twisted. This wiring method ensures lasting EMC (sturdiness).

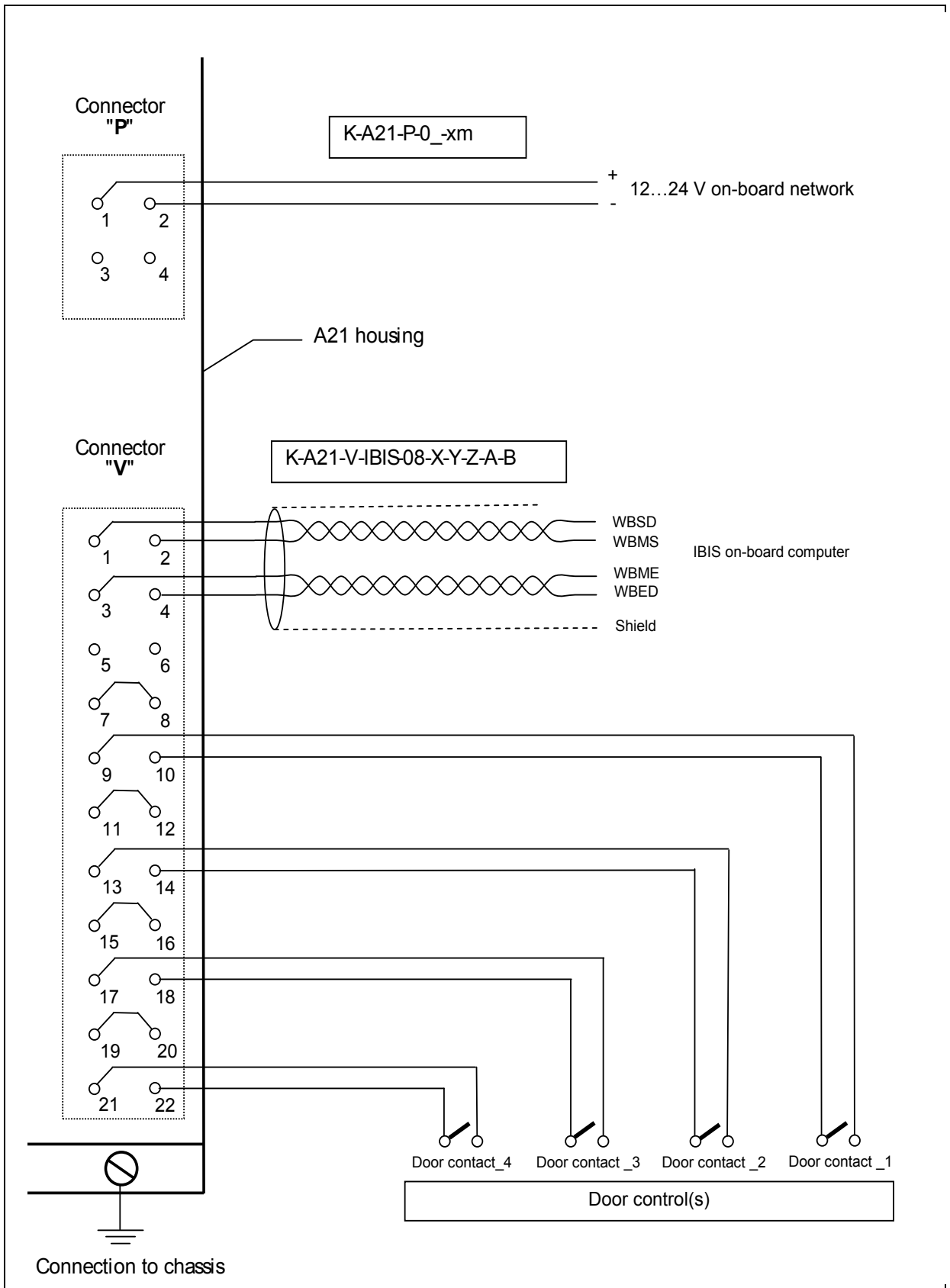

Fig. 15: Overview of door signals by means of potential free contacts

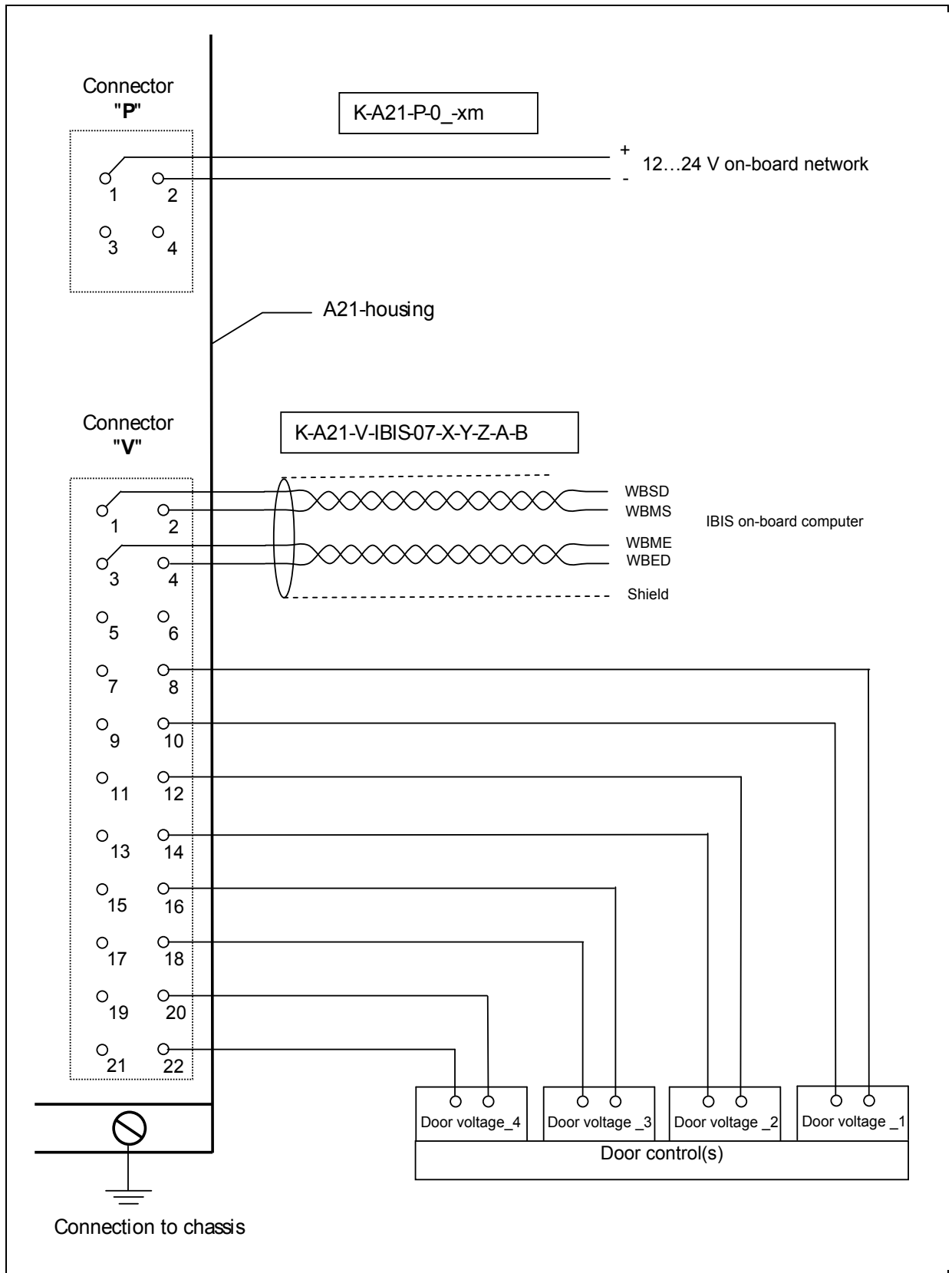

Fig. 16: Overview of door signals by means of external control voltage (any polarity)

## 11 Abbreviations, terms

APC	Automatic Passenger Counter
CAN	Controller Area Network
DC	Direct current
ESD	Electro Static Discharge
EMC	Electromagnetic Compatibility
IRMA	Infrared Motion Analyzer
IBIS	Integriertes Bordinformationssystem - Integral on-board information system
NVSRAM	Non Volatile Static Random Access Memory
OBC	On-board computer
potential free	Same meaning as "electrically isolated" or "galvanically isolated"
SPI	Serial Peripheral Interconnection
SSI	Serial Synchronous Interconnection
SSM	Schnittstellenmodul - Interface module
SV	Stromversorgung - Power supply